

Nous vous remercions d'avoir choisi nos produits et de la confiance que vous nous témoignez.

Veillez prendre connaissance des informations suivantes et des précautions à prendre avant l'installation de votre cabine de douche.

## IMPORTANT

1. Assurez-vous que la cabine de douche n'a aucun défaut avant l'installation. En cas de défaut ne procédez pas à l'installation.
2. Vérifier que tous les composants sont présents.
3. Assurez-vous que le modèle est bien celui commandé et que les dimensions sont exactes.

Veillez prendre connaissance des informations suivantes et des précautions à prendre avant l'installation de votre cabine de douche.

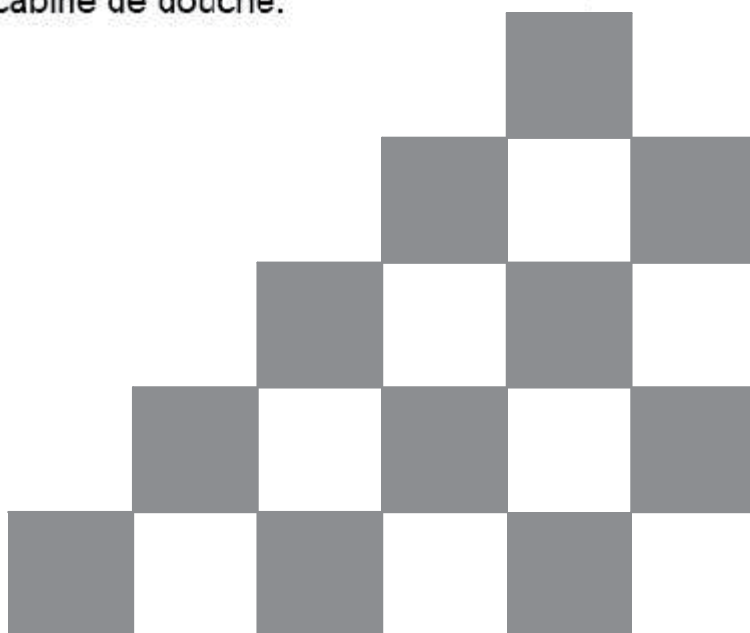

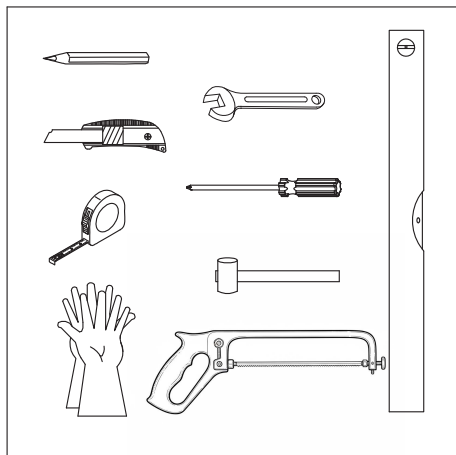
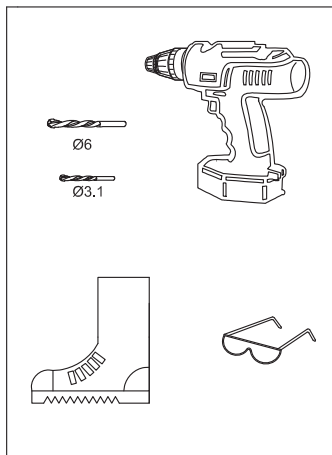
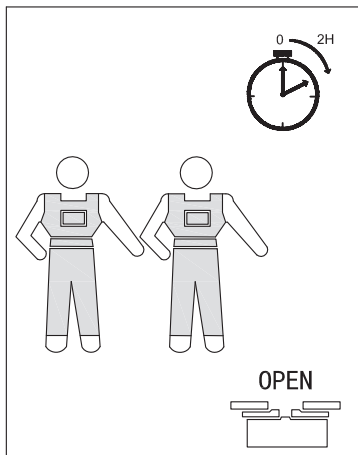
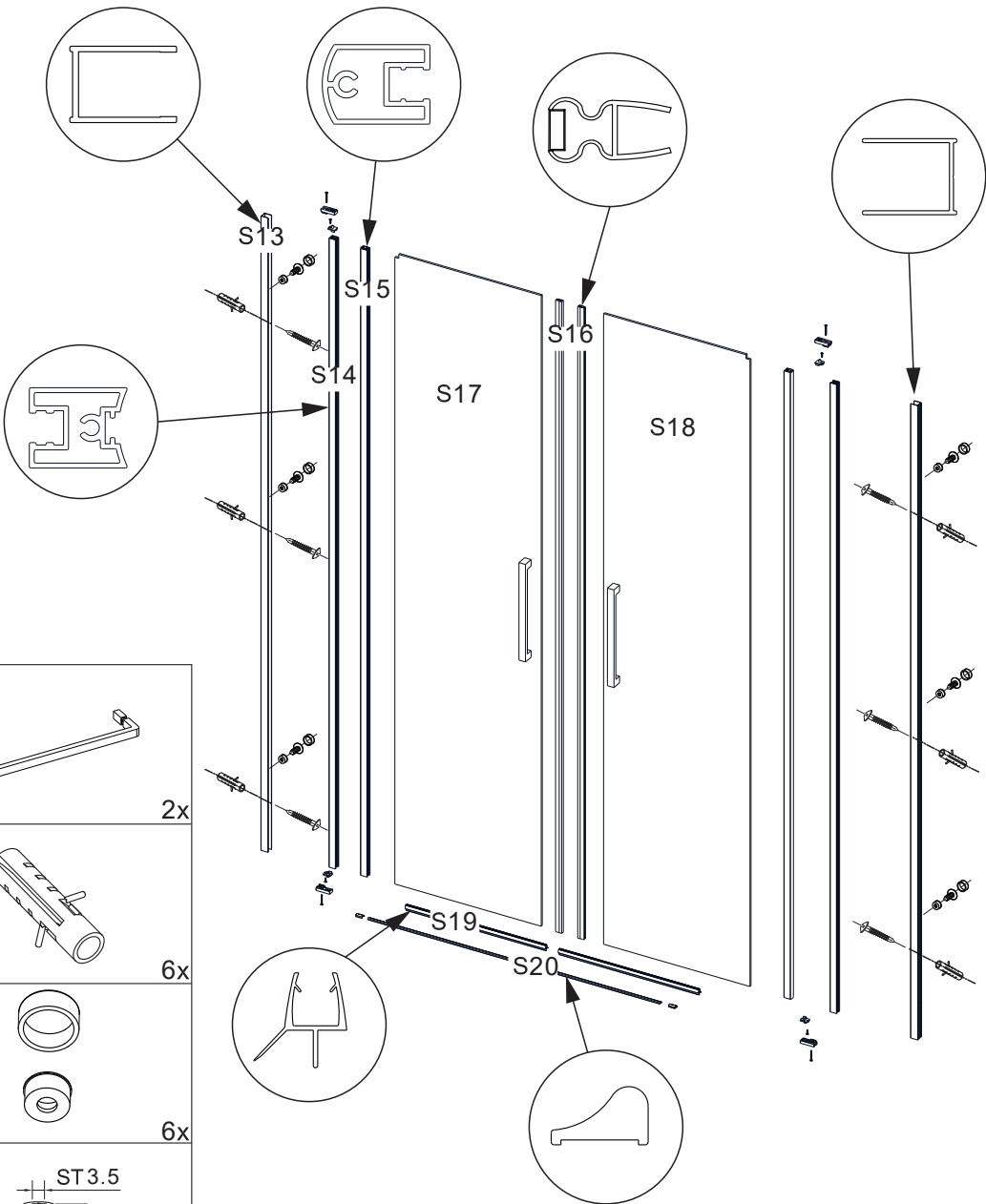
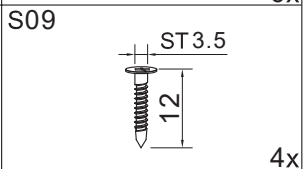
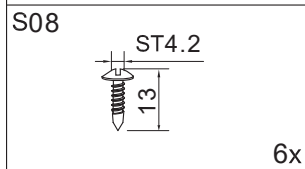
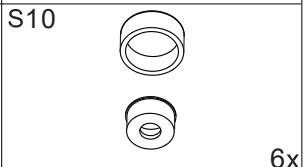
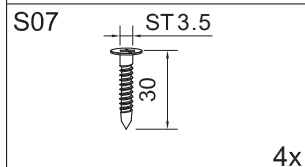
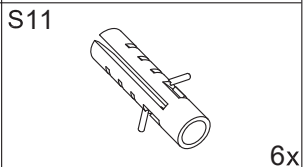
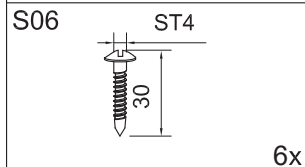
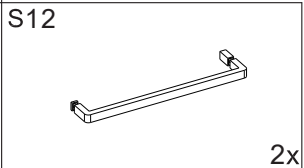
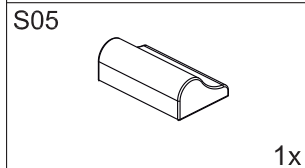
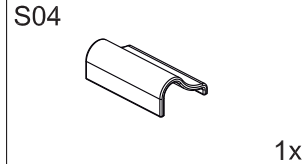
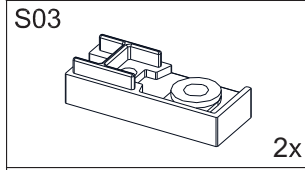
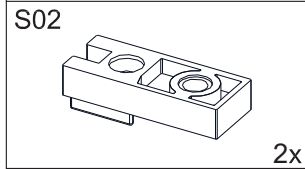
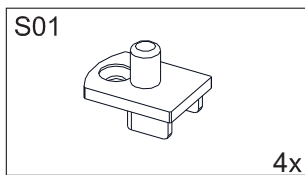
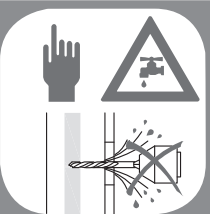
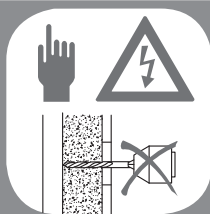

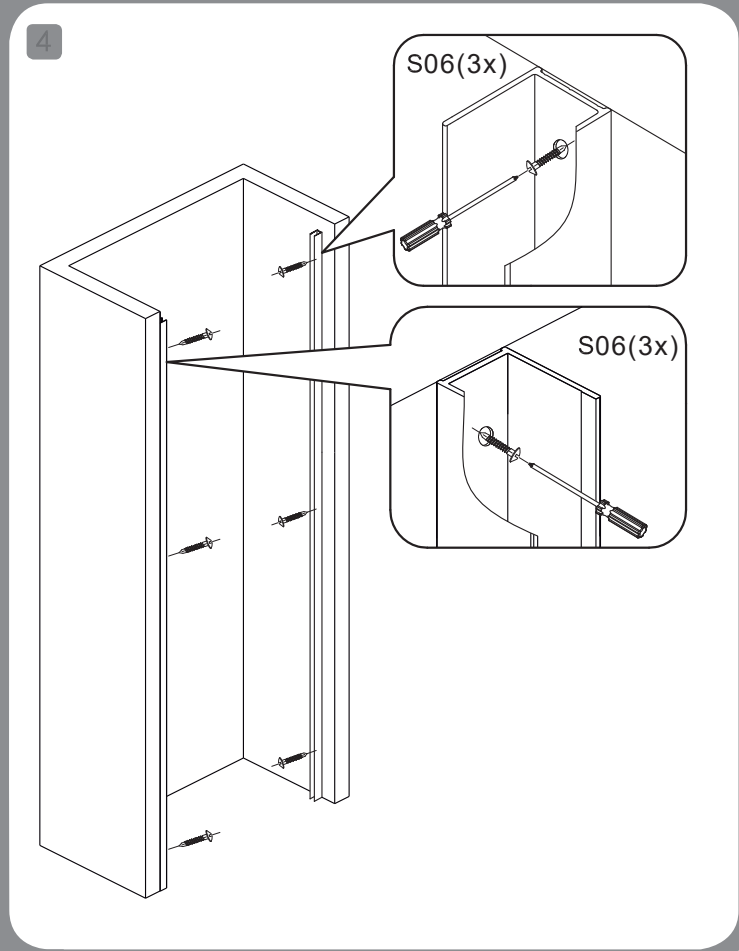
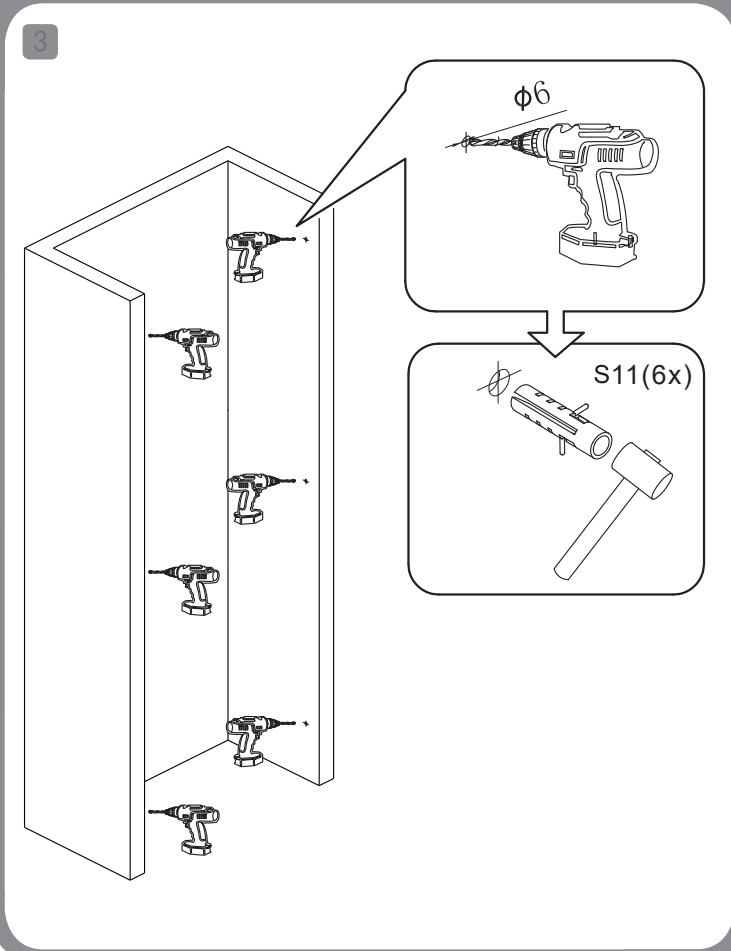
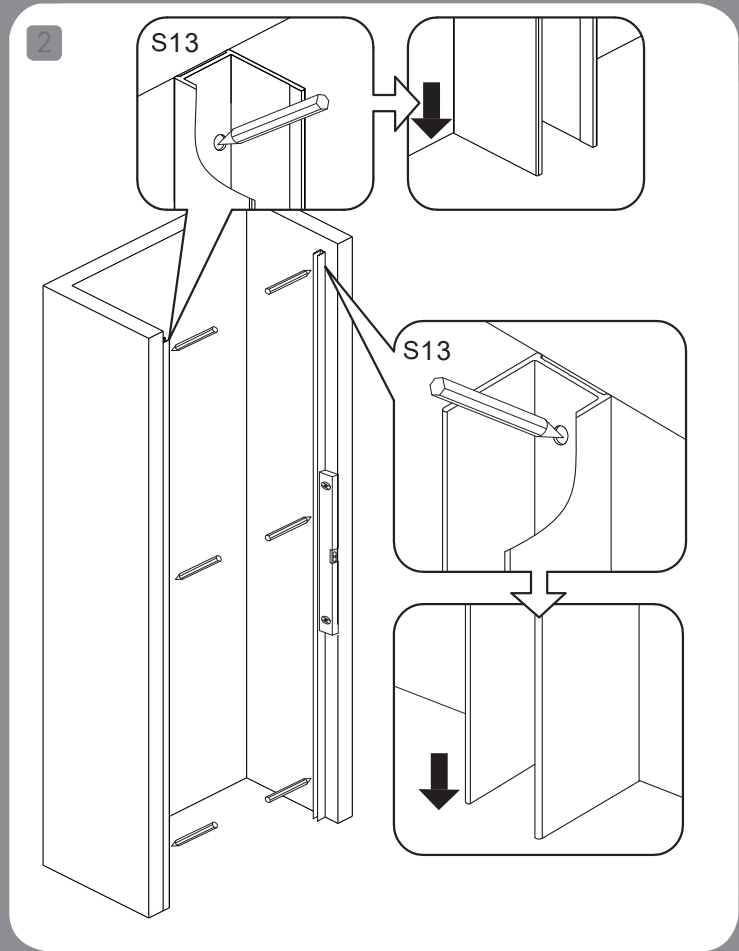
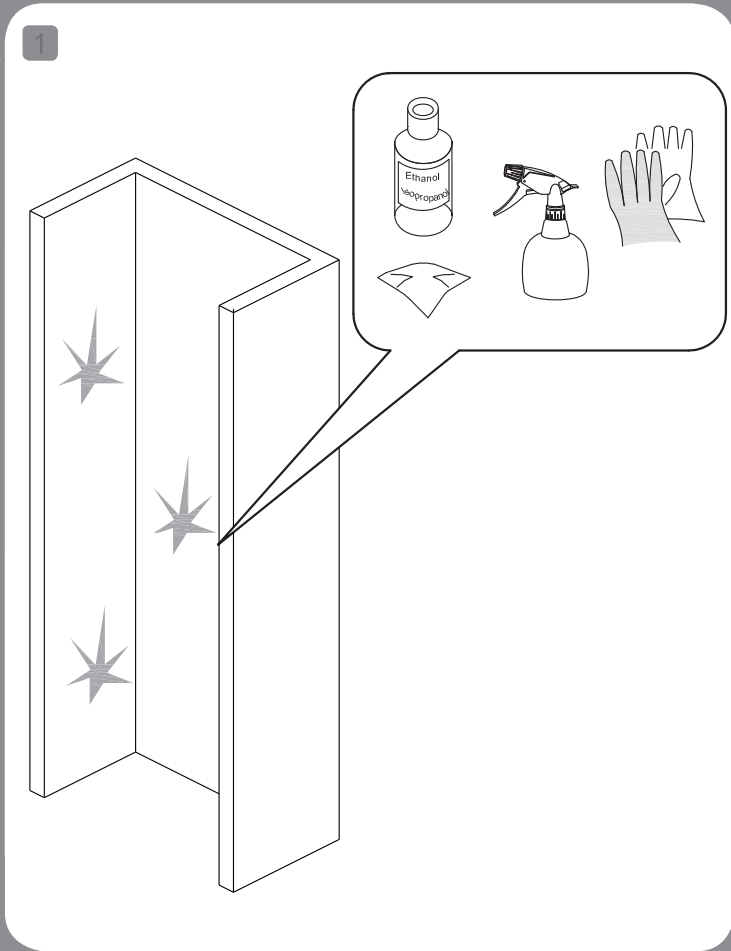
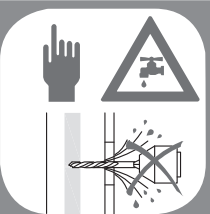
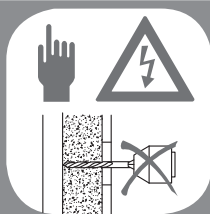

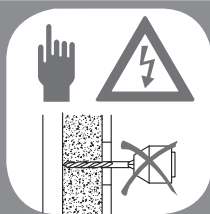

5

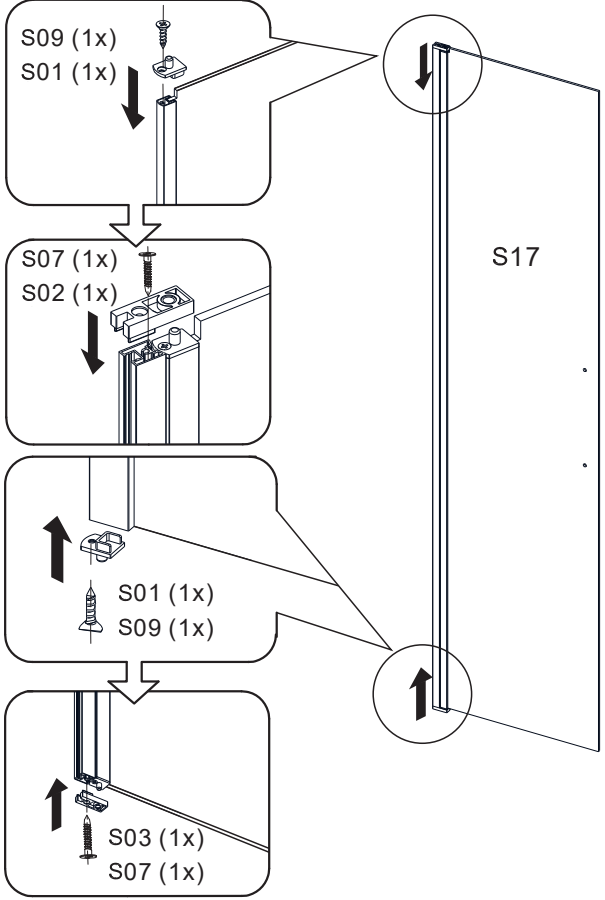

6

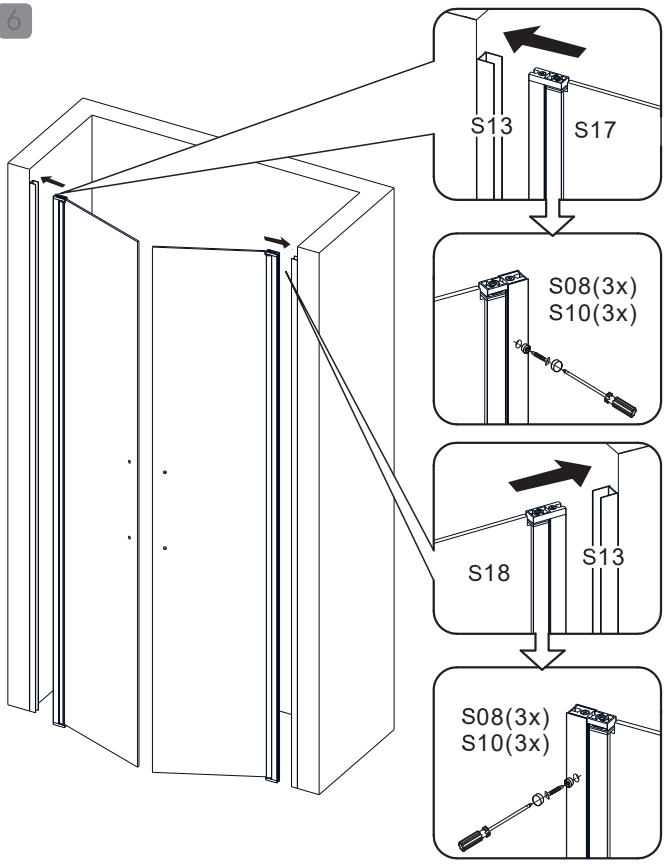

7

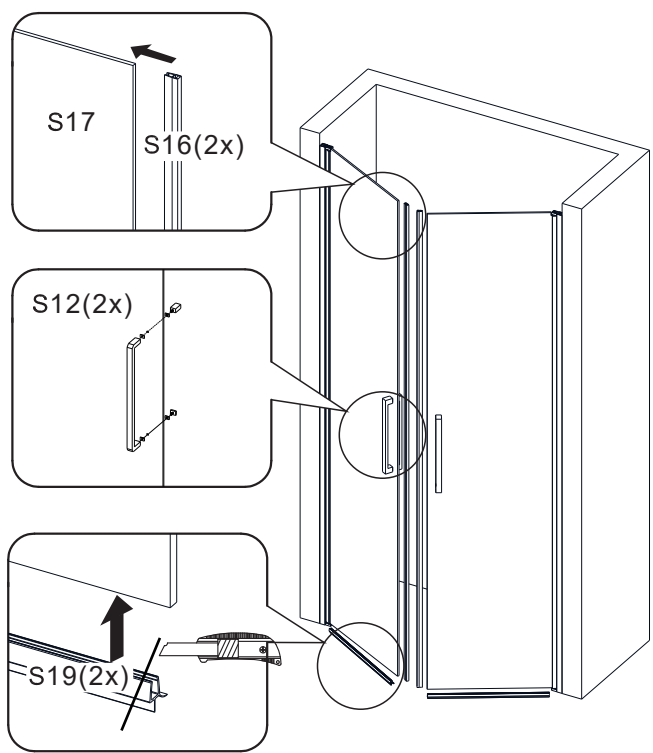

Coupez les joints S19 à la dimension des portes

8

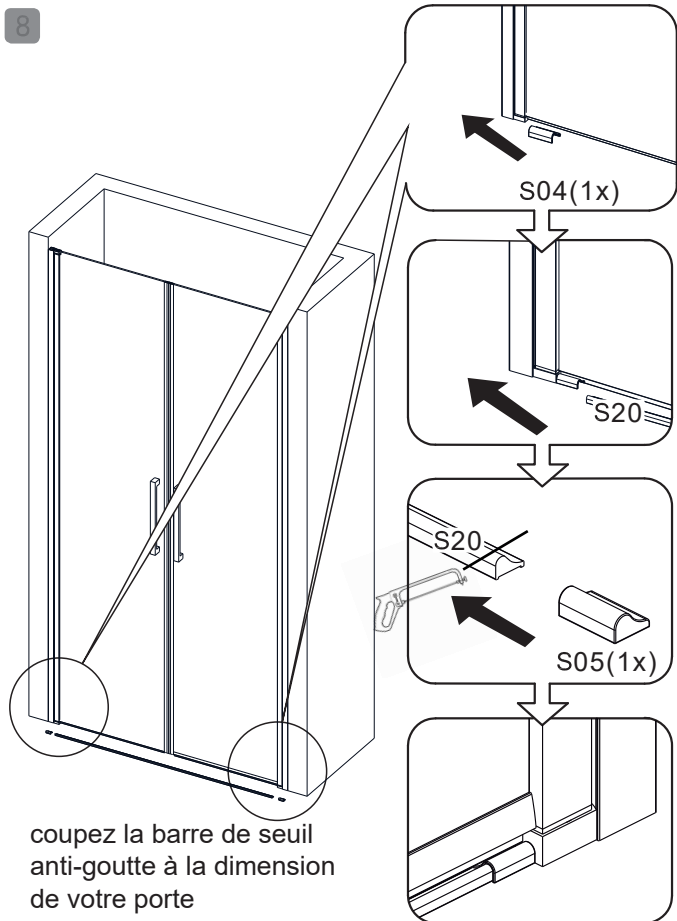

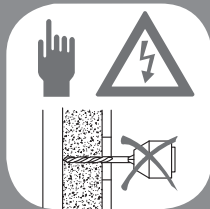

9

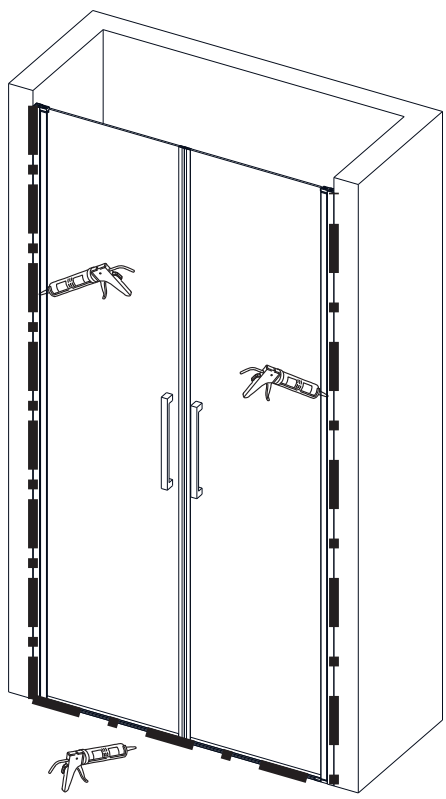

# CONSEILS D'ENTRETIEN

La douche doit être nettoyée après chaque utilisation.

Afin d'éviter la formation de calcaire, utiliser une raclette, un chiffon doux ou une peau de chamois. Rincer les résidus de savon avec de l'eau claire après chaque usage. Tous les profileurs en aluminium doivent également être nettoyés pour éviter les résidus de calcaire.

- Ne pas laisser le calcaire s'accumuler.
- Si, malgré tout, vous constatez une accumulation de calcaire, utiliser de l'eau mélangé à du vinaigre.
- Afin de protéger la qualité de finition de votre douche, vous devez la nettoyer avec des nettoyants non abrasifs et non corrosifs.

